



Fender Eliminator Kit

APPLICATION

YEAR	MODEL
2008-2014	Honda CBR1000RR

PRODUCT

070BG120202	Fender Eliminator Kit
-------------	-----------------------

! This product is not DOT approved. Yoshimura R&D of America, Inc. is not liable or responsible for any resulting event caused by the installation of this product. Check with local laws and regulations for compliance prior to installation and use. This product is not intended for use on public highways.

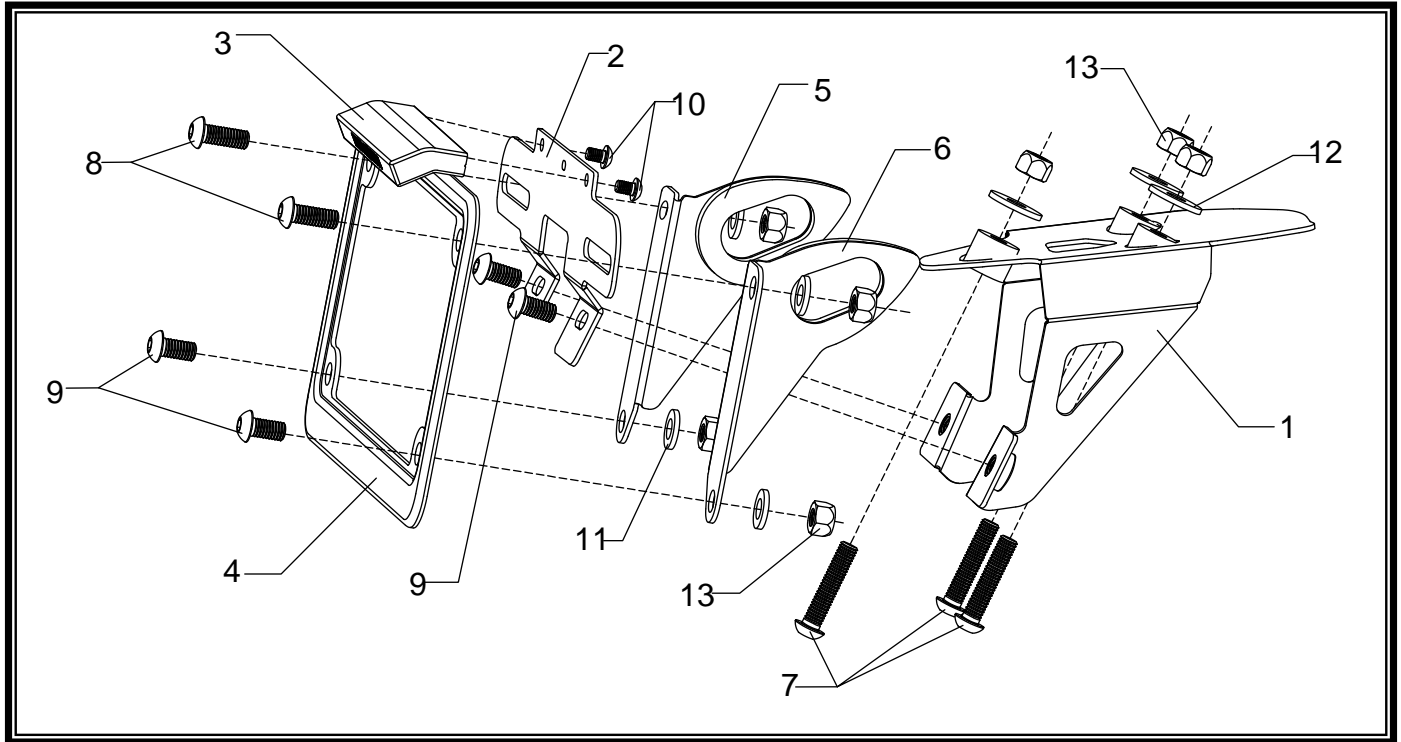

No.	Part #	Description	Qty
1	1202-FEB-00	Yoshimura Fender Eliminator Bracket	1
2	12200-FEBKT	Yoshimura License Plate Bracket	1
3	070BG-LH-K	Yoshimura LED Fender Eliminator Light	1
4	070BG-LPF	Yoshimura Aluminum License Plate Frame	1
5	12200-TSB-L	Left Turn Signal Bracket	1
6	12200-TSB-R	Right Turn Signal Bracket	1
7	M6X30BHS	6mm x 30mm Button Head Screw	3
8	M6X16BHS	6mm x 16mm Button Head Screw	2
9	M6X12BHS	6mm x 12mm Button Head Screw	4
10	M4X6BHS	4mm x 6mm Button Head Screw	2
11	6MMWASHER	6mm Washer	4
12	6MMWASHERL	6mm Large Washer	3
13	6MMLN	6mm Nylon Lock Nut	7
**	94785-01-ND	Butt Connectors	2
**	ZT-400	Cable Ties	3
**	17029	Yoshimura Sticker Sheet	1

-TOOLS REQUIRED-

Metric Socket Set • Combination Wrench Set • Metric Allen Wrench Set

Note: This kit is designed to fit the 2010-2014 Honda CBR1000RR with no modifications except as indicated below. For 2008 and 2009 model Honda CBR1000RR's, the following components will need to be purchased and installed as per OEM instructions.

<i>Honda Part No.</i>	<i>Description</i>	<i>Qty.</i>
80114-MFL-D20	COWL, RR. CENTER	1
90127-KF0-770	COLLAR (6X4)	3

-REMOVAL-

- 1. Remove passenger seat.**
- 2. Disconnect turn signal and license plate light connectors.**
- 3. Remove stock fender assembly by removing the (3) bolts securing fender assembly to subframe.**
- 4. Remove left and right turn signals from stock fender assembly by removing the screw and plate securing turn signal to fender assembly.**
- 5. Cut the stock license plate light connector from the stock fender assembly. Be sure to cut at least a 6" section of wire from the connector. Using the connectors in the kit, connect the Yoshimura Fender Eliminator wires to the stock license plate light connector as follows: Red wire goes to the brown wire w/ white stripe; Black wire goes to green wire.**

-INSTALLATION-

- 1. Using the supplied nuts and washers, install Yoshimura fender eliminator bracket as shown in the parts diagram.**
- 2. Install Yoshimura LED license plate light onto license plate bracket using the (2) screws provided in the kit. See diagram for proper orientation.**
- 3. Install license plate bracket onto fender eliminator bracket. See diagram for proper orientation and order of hardware.**
- 4. Route wiring through hole in bracket, then through tail section to stock location. Using the connectors in the kit, connect the Yoshimura Fender Eliminator wires to the stock license plate light connector as follows: Red wire goes to the brown wire w/ white stripe; Black wire goes to green wire. Connect license plate light connector and turn signal connectors to stock harness.**
- 5. Install stock turn signals onto Yoshimura turn signal brackets and secure using the stock turn signal plate and screw.**
- 6. Install turn signal bracket onto Yoshimura Fender Eliminator using supplied hardware. See diagram for proper orientation.**
- 7. Use provided cable ties to secure license plate light and turn signal wires.**
- 8. Re-install passenger seat.**
- 9. Check for function of license plate light and turn signals and that all brackets and components are secure prior to riding.**